

4" AND GREATER HOT TAP FOR FIRE SERVICE,  
FIRE HYDRANTS, AND NEW WATER MAINS

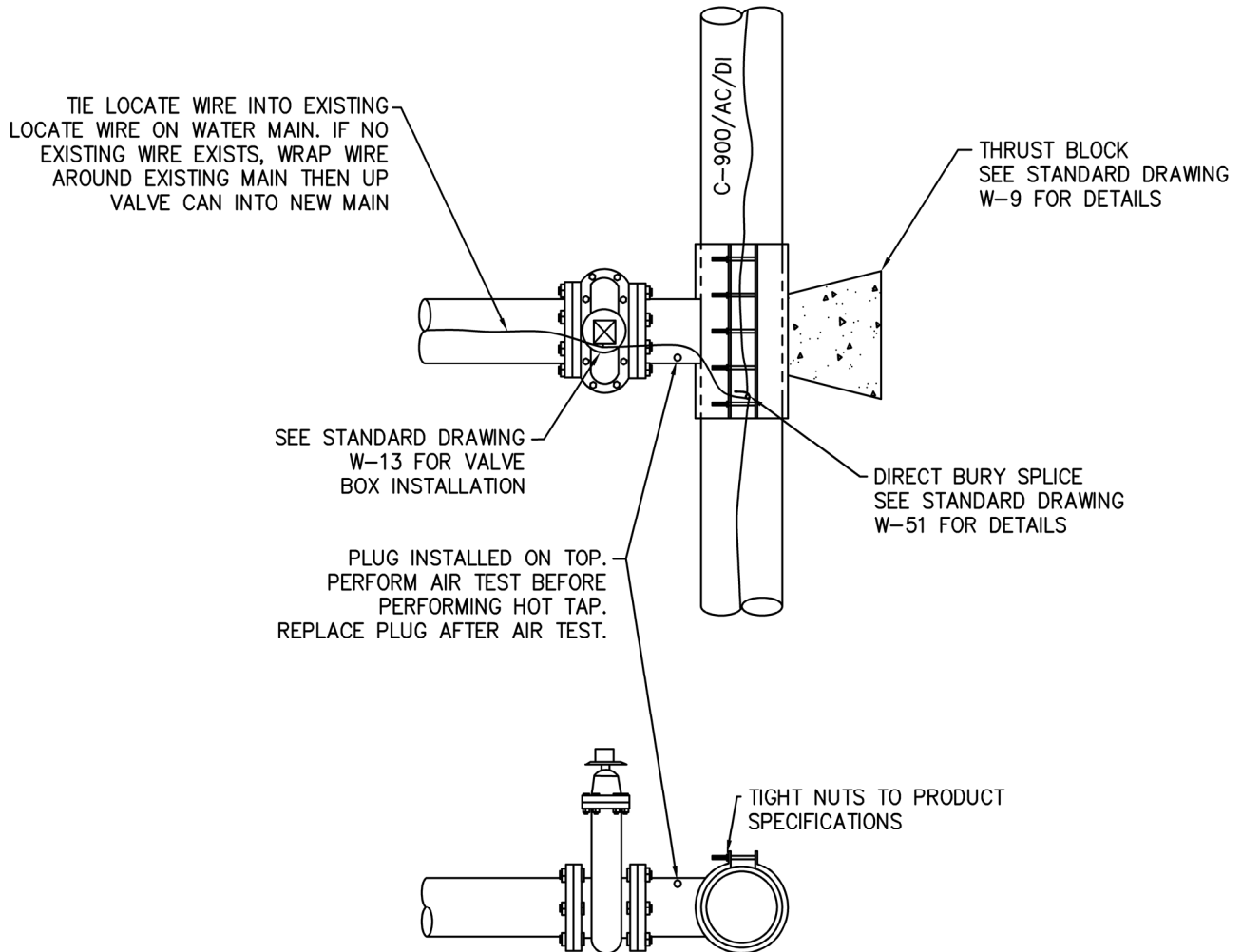

NOTES:

1. CLEAN EXISTING WATER MAIN, TAPPING SADDLE, AND NEW GATE VALVE WITH SODIUM HYPOCHLORITE SOLUTION OR EQUIVALENT.
2. ALL HOT TAPS 4" AND GREATER SHALL HAVE AN AIR TEST PERFORMED BY THE CONTRACTOR PRIOR TO PERFORMING THE HOT TAP.
3. AIR TEST SHALL HOLD 50 PSI FOR A MINIMUM OF 5 MINUTES OR AS LONG AS DIRECTED BY FIELD INSPECTOR.
4. THRUST BLOCK SHALL BE INSTALLED PER STANDARD DRAWING W-9.
5. 12 GAUGE BURY LOCATE WIRE SHALL BE INSTALLED TO THE EXISTING MAINS THAT DO NOT HAVE LOCATE WIRE. LOCATE WIRE THEN SHALL BE WRAPPED AROUND EXISTING WATER MAIN AND RAN UP VALVE CAN AND OUT TO NEW WATER MAIN.



CITY OF COEUR D'ALENE STANDARD DRAWING

**4" AND GREATER  
HOT TAP**

APPROVED BY:

*Chris Bosley*  
CITY ENGINEER, PE 10804

10/1/24  
DATE:

DWG NO.

W-52