

NOTES THIS DETAIL:

1. TAP SADDLES ARE ONLY USED WHEN CONNECTING A NEW SEWER LATERAL TO AN EXISTING SEWER MAIN AND MUST BE PRE-APPROVED BY THE CITY.
2. ALL SADDLES SHALL BE GPK FOR CIPP LINED OR PVC PIPES AND CB-STYLE ROMAC FOR CONCRETE PIPES AND SHALL BE SIZED BASED ON THE OUTSIDE DIAMETER OF THE SEWER MAIN OR PLASTIC LINED PIPE (CIPP).
3. TWO (2) STAINLESS STEEL (SERIES 300 OR BETTER) THREADED STRAPS CAPABLE OF 60 LBS. TORQUE SHALL SECURE SADDLE TO SEWER MAIN. GLUED OR CEMENTED SADDLES ARE NOT ACCEPTABLE.
4. UNLESS PRE-APPROVED BY THE CITY, ALL TAPS SHALL BE ORIENTATED AT 45° ABOVE SEWER MAIN SPRING LINE (ABOVE HORIZONTAL). TAPS ON PIPE CROWN OR SPRING LINE ARE NOT ACCEPTABLE.
5. ALL TAPS TO EXISTING SEWER MAIN SHALL BE CLEAN CUT BY DRILLING OR CORING METHOD ONLY. NO "BREAK-IN" OR HAMMERING TAPS WILL BE ALLOWED. PRESENT CORED TAP COUPON FOR WASTEWATER UTILITY INSPECTION.
6. IF TAPPING A NEW SADDLE ONTO A CIPP LINED SEWER MAIN, GENTLY DEMO AND REMOVE CONCRETE/CLAY HOST PIPE AND ATTACH NEW SADDLE DIRECTLY ONTO THE CIPP LINED PIPE.

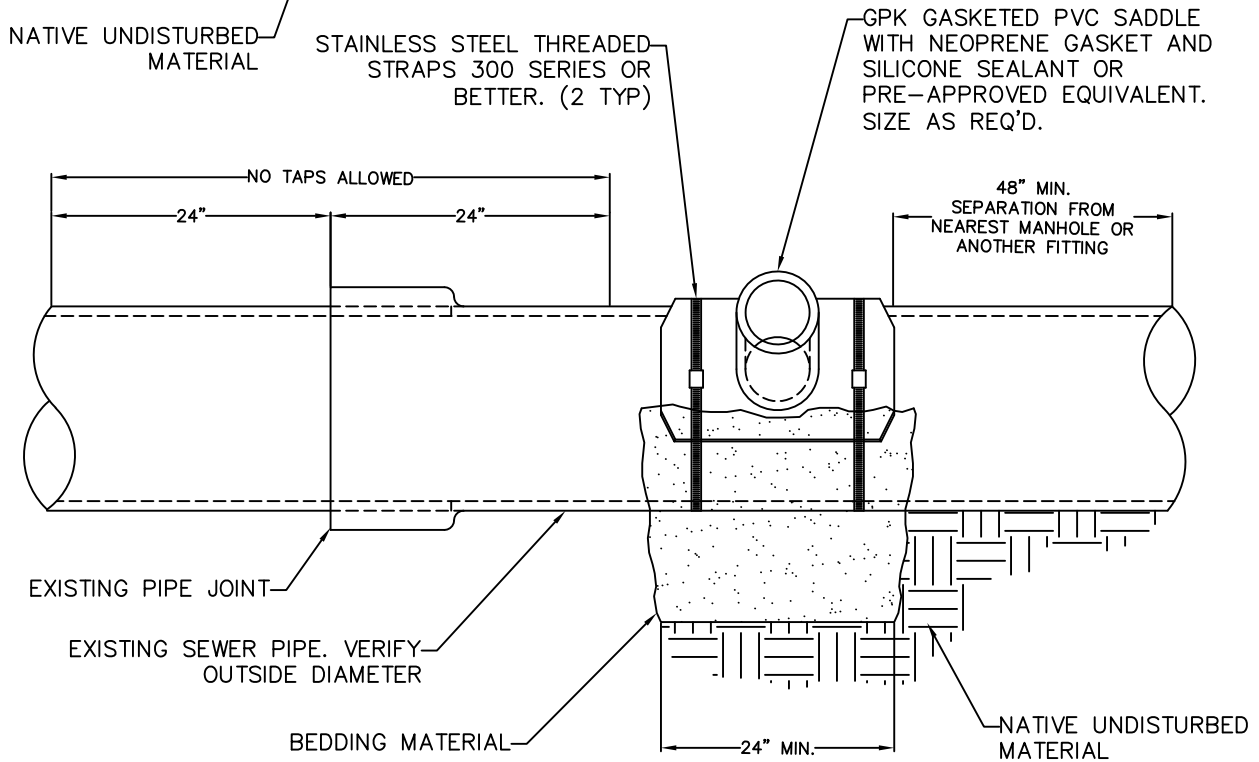
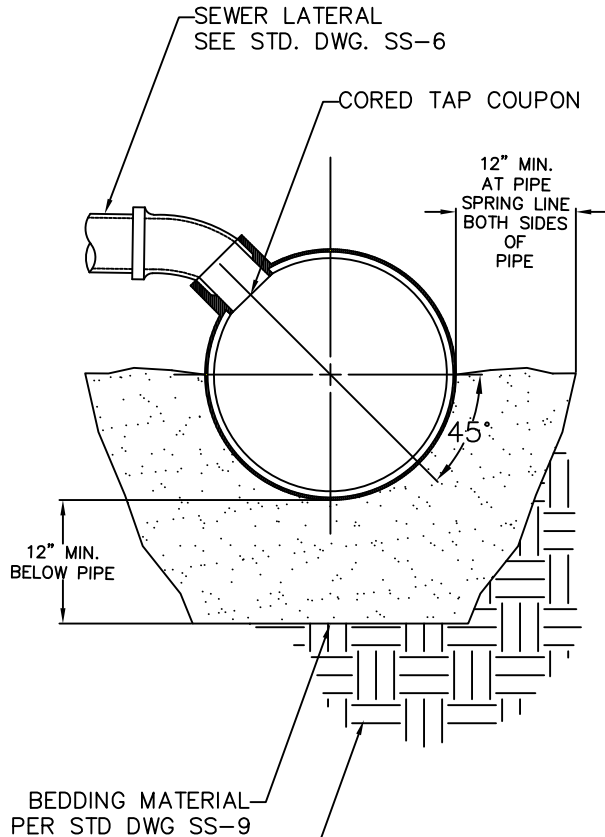

CITY OF COEUR D'ALENE STANDARD DRAWING

SEWER TAPPING SADDLE

APPROVED BY:

Chris Bosley
CITY ENGINEER, PE 10804

10/1/24
DATE:

DWG NO.

SS-8