

PLAN VIEW

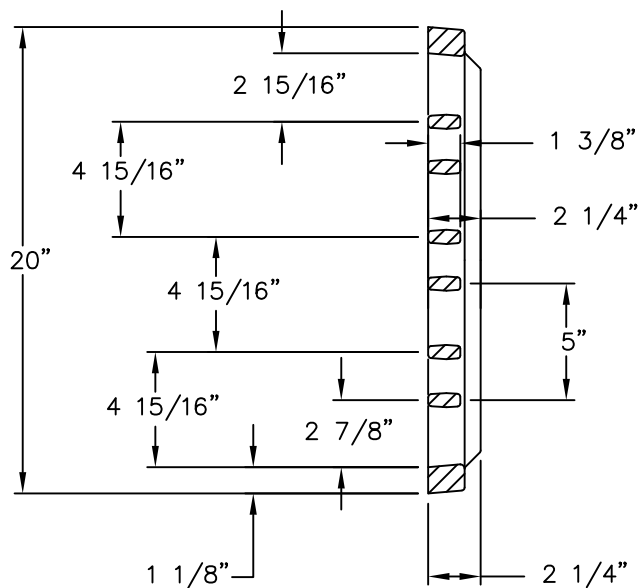

SECTION VIEW

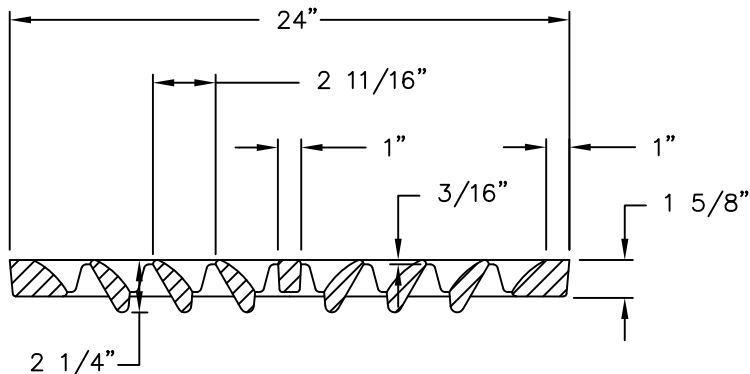

SECTION VIEW

GENERAL NOTES

1. THE NAME OF THE MANUFACTURER AND DIRECTION OF FLOW SHALL BE EMBOSSED ON THE TOP SURFACE OF EACH GRATE. LETTERING TO BE RECESSED 1/16".
2. FRAME SHALL BE GRAY IRON CONFORMING TO A.S.T.M. A48-90, GRADE 30. THE GRATE SHALL BE DUCTILE IRON CONFORMING TO A.S.T.M. A536-84 GRADE 80-55-06.
3. DIMENSIONS SHALL HAVE ±1/16" TOLERANCE, EXCEPT AS NOTED.
4. EDGES SHALL HAVE 1/8" RADIUS, 1/8" CHAMFER OR COMPLETE DEBURRING.
5. THE FRAME SHALL BE MANUFACTURED IN ACCORDANCE WITH STANDARD FOR TYPE 1 FRAME.
6. WELDING IS NOT PERMITTED.



CITY OF COEUR D'ALENE STANDARD DRAWING

CATCH BASIN GRATE
2 - WAY

APPROVED BY:

Chris Bosley
CITY ENGINEER, PE 10804

10/1/24
DATE:

DWG NO.

SD-4A