

Below Inlet Gate Filter
Not to Scale

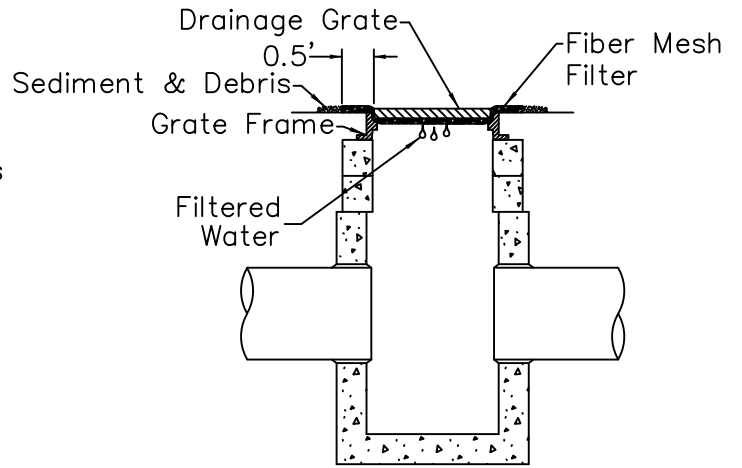

Fiber Mesh Filter
Not to Scale

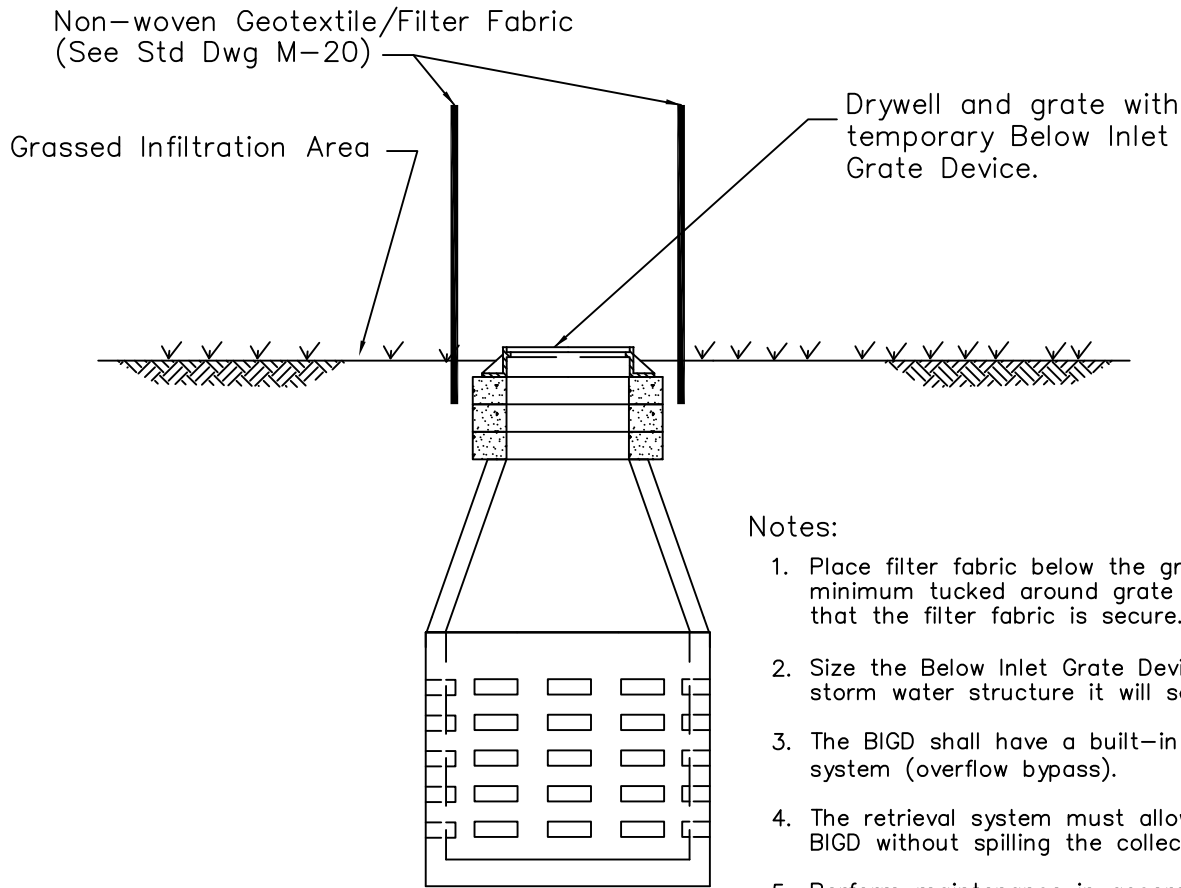

Drywell
Not to Scale

Notes:

1. Place filter fabric below the grate with 0.5' minimum tucked around grate sides to ensure that the filter fabric is secure.
2. Size the Below Inlet Gate Device (BIGD) for the storm water structure it will service.
3. The BIGD shall have a built-in high-flow relief system (overflow bypass).
4. The retrieval system must allow removal of the BIGD without spilling the collected material.
5. Perform maintenance in accordance with Std Dwg M-16.



CITY OF COEUR D'ALENE STANDARD DRAWING

INLET PROTECTION

APPROVED BY:

Chris Bushy
CITY ENGINEER, PE 10804

10/1/24
DATE:

DWG NO.

M-19