



# CITY OF COEUR D'ALENE BUILDING SERVICES DEPARTMENT

CITY HALL – 710 E. MULLAN AVENUE  
COEUR D'ALENE, IDAHO 83814-3964  
(208) 769-2267 – (208) 769-2237 FAX  
<http://building.cdaid.org>

## EGRESS WINDOWS

MINIMUM CLEAR OPENABLE WIDTH

|----- 20" -----|

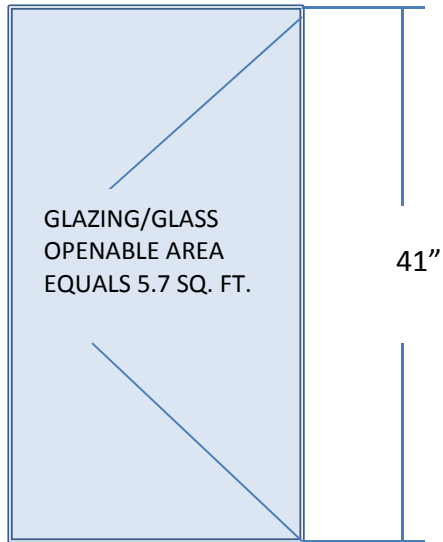

MINIMUM SIZE WINDOW FOR 20 INCH CLEAR WIDTH

CLEAR OPENING WIDTH

|-----34" -----|

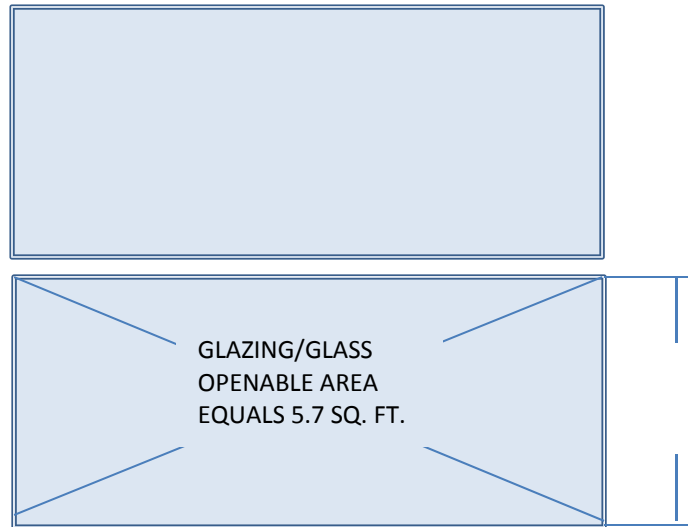

24"  
CLEAR  
MINIMUM

MINIMUM SIZE WINDOW FOR A 24 INCH CLEAR HEIGHT

44"

MEASURED FROM WINDOW CLEAR OPENING TO FLOOR

EMERGENCY ESCAPE AND RESCUE OPENINGS SHALL HAVE THE BOTTOM OF THE WINDOW CLEAR OPENING NOT GREATER THAN 44 INCHES MEASURED FROM THE FLOOR.

IRC R310.1.1

EGRESS WINDOWS SHALL HAVE A MINIMUM NET CLEAR OPENING AREA OF 5.7 SQ. FT. THE MINIMUM HEIGHT SHALL BE 24 INCHES. THE MINIMUM WIDTH SHALL BE 20 INCHES.

CLEAR OPENING HEIGHT TIMES CLEAR OPENING WIDTH SHALL NOT BE LESS THAN 5.7 SQ. FT.

EXCEPTION: GRADE FLOOR OPENINGS MAY HAVE A MINIMUM NET CLEAR OPENING OF 5 SQ. FT.



## EMERGENCY ESCAPE AND RESCUE OPENINGS

## EGRESS WINDOW WELL

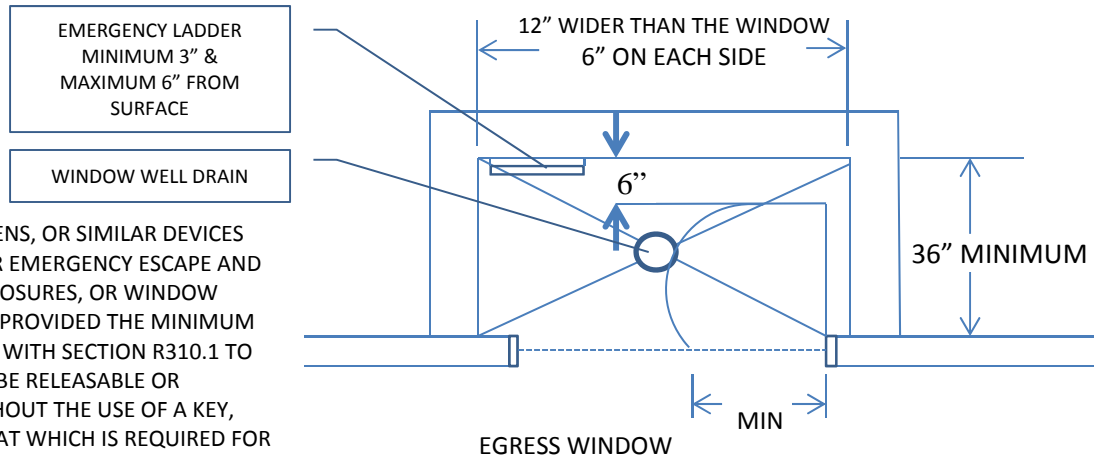

R310.4 BARS, GRILLS, COVERS, SCREENS, OR SIMILAR DEVICES ARE PERMITTED TO BE PLACED OVER EMERGENCY ESCAPE AND RESCUE OPENINGS, BULKHEAD ENCLOSURES, OR WINDOW WELLS THAT SERVE SUCH OPENING, PROVIDED THE MINIMUM NET CLEAR OPENING SIZE COMPLIES WITH SECTION R310.1 TO R310.1.3 AND SUCH DEVICES SHALL BE RELEASABLE OR REMOVABLE FROM THE INSIDE WITHOUT THE USE OF A KEY, TOOL, OR FORCE GREATER THAN THAT WHICH IS REQUIRED FOR NORMAL OPERATION OF THE ESCAPE AND RESCUE OPENING.

### PLAN VIEW

LADDER CANNOT ENCRANCH MORE THAN 6 INCHES INTO THE REQUIRED 36 INCH OPENING WIDTH WITH A MAXIMUM SPACING OF THE RUNGS OF 18 INCHES ON CENTER.

EMERGENCY ESCAPE LADDER OR STEPS REQUIRED WHEN DEPTH FROM WELL FLOOR TO GRADE ABOVE EXCEEDS 44 INCHES.

LADDER SHALL PROJECT AT LEAST 3 INCHES FROM THE WALL OF THE WINDOW WELL.

WELL DRAIN TO DRY WELL OR OTHER APPROVED LOCATION

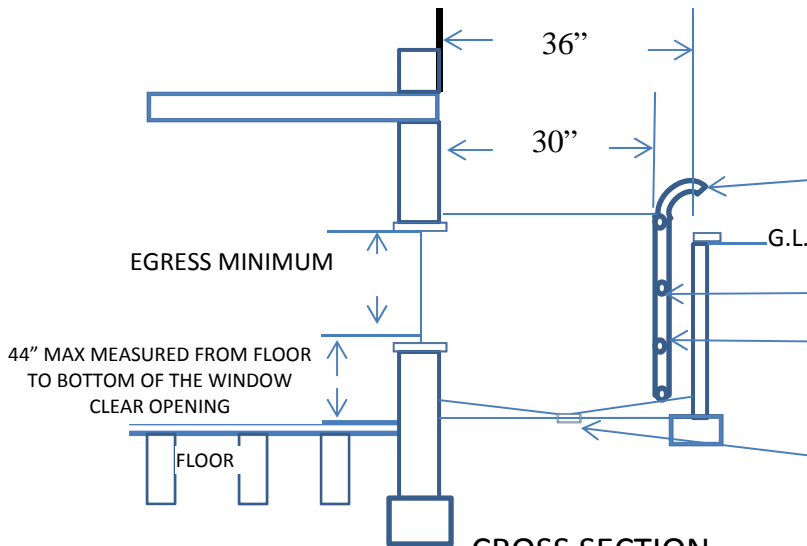

### CROSS SECTION

WINDOW WELLS USED FOR EMERGENCY EGRESS FROM BASEMENTS OR FLOORS LOWER THAN GRADE SHALL MEET THE FOLLOWING SIZE REQUIREMENTS FROM IRC SECTION R310.2. THE MINIMUM HORIZONTAL AREA OF THE WINDOW WELL SHALL BE 9 SQ. FT. WITH A MINIMUM HORIZONTAL PROJECTION OF 36 INCHES. THE AREA OF THE WINDOW WELL SHALL ALLOW THE EMERGENCY ESCAPE AND RESCUE OPENING TO BE FULLY OPENED.

EXCEPTION: THE LADDER OR STEPS REQUIRED BY SECTION R310.2.1 SHALL BE PERMITTED TO ENCRANCH A MAXIMUM OF 6 INCHES INTO THE REQUIRED DIMENSION OF THE WINDOW WELL.

R310.2.1 WINDOW WELLS WITH A VERTICAL DEPTH GREATER THAN 44 INCHES SHALL BE EQUIPPED WITH A PERMANENTLY AFFIXED LADDER OR STEPS USABLE WITH THE WINDOW IN A FULLY OPENED POSITION. LADDERS OR STEPS REQUIRED BY THIS SECTION SHALL NOT BE REQUIRED TO COMPLY WITH SECTIONS R311.7 AND R311.8. LADDERS OR RUNGS SHALL HAVE AN INSIDE WIDTH OF AT LEAST 12 INCHES. SHALL PROJECT AT LEAST 3 INCHES FROM THE WALL AND SHALL BE SPACED NOT MORE THAN 18 INCHES ON CENTER VERTICALLY FOR THE FULL HEIGHT OF THE WINDOW WELL.